



Know-how in food processing!



Fish skinning machines

Cut down costs by first-class technology

Quick cleaning and optimum hygiene

- The NOCK fish skinning machines have not only a modern, but also **hygienic design**, which naturally complies to the latest hygienic regulations.
- The machine casing, belt frame, transport roller, blade holder etc. are made of **high quality stainless steel**. The conveyor belts and pressure rollers are made of foodgrade plastics.
- Due to the NOCK POWER PLATES® it is possible to construct the casings of the machines with **large smooth surfaces** which are particularly hygienic and easy to clean.
- At the conveyORIZED fish skinning machines, the **NOCK EASY-FLOW® safety cover** prevents the build-up of product surpluses on the mountings of the blade holder and pressure unit during processing.
- All NOCK fish skinners are equipped with lockable castors. This eases transportation to the cleaning area.

Excellent yield

The NOCK fish skinning machines convince customers all over the world not only by their reliable functioning and low maintenance costs but also by **very low loss of expensive fish**. The maximum values of this important criterion is reached from the NOCK fish skinners by

- an advanced construction of all machine components for the skinning (blade holder, blade, transport roller, pressure unit, infeed conveyor belt)
- the high precision construction and mounting of these components at NOCK
- the NOCK POWER PLATES® which guarantee long lasting precision of the machines
- innovative technologies like the NOCK ACTIVE SKIN GRIPPER®

The best possible yield is only guaranteed when processing with original NOCK TOP H blades!

The NOCK EASY-FLOW®-safety cover

The covers of the NOCK fish skinning conveyor belt machines are **constructed tunnel-like**:



Quick and easy to clean: NOCK fish skinning machine after removing conveyor belts, pressure roller and blade holder

Conveyor belts, pressure roller, blade holder and output table can be removed and replaced for cleaning purposes within seconds without any tools. Therefore soiled parts are easily accessible. The transport roller can be turned by hand. The conveyor belt frames can be folded back so that the inside of the belts can be cleaned. The conveyor belts can also be easily removed from their frames for thorough cleaning. The Freeze Drum Skinner TFE 350 has a special cleaning modus.

Bearings made of stainless steel are more resistant to improper cleaning of the machines.



All machine parts which could obstruct the flow of the product, e.g. the mountings and handles of the blade holder, the mountings of the pressure device and of the conveyor belts, are located outside the tunnel-like safety cover.

The advantages:

- Reliable product flow („easy flow“)
= higher processing safety
- Hardly any accumulation of residues on the mountings during processing = better processing hygiene and faster cleaning of the machine

A safety switch stops the machine once the cover is opened. A safety bolt hinders reliably that the opened safety cover accidentally falls closed.

The NOCK EASY-FLOW® safety cover complies to the European safety standard EN 12355 and contributes to the high occupational safety of the NOCK fish skinning machines.

NOCK POWER PLATES® for particular robustness and service friendliness

The mechanically highly strained machine components such as drive, transport roller and blade holder are mounted in **solid, 15 mm thick base plates**, the **NOCK POWER PLATES®**, which are located in the machine casing.

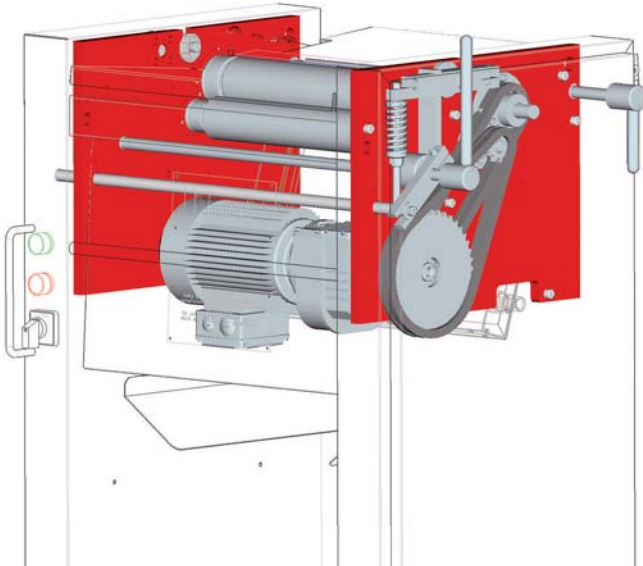

This construction of the NOCK machines has been proven since 1990 and guarantees among others:

- **Long lasting precision**
The NOCK POWER PLATES® guarantee an excellent **bearing alignment and precise positioning of the machine parts**. This cannot be reached with the usual positioning of such machine parts on the casing.
- **No material fatigue**
With a 15 mm thickness, the NOCK POWER PLATES® are resistant to material fatigue. They make the NOCK fish skinners especially sturdy and durable and are also extremely suitable for the several shift constant industrial operation with intensive machine use.
- **Extraordinary service friendliness**
All components are very easily accessible once the side covers are opened.

Every service technician will understand at once the clear and low-maintenance construction of the NOCK machines. A specialist is not required for servicing. **Also therefore the NOCK machines are highly appreciated and successfully sold all over the world.**



Top quality - Made in Germany

NOCK is an owner run German family business, which since 1990 constructs and successfully sells modern machines for the food processing industry worldwide. In close contact to processing plants and distributors, the machines are constantly further developed. Of course the latest hygiene and safety standards are respected.



F. Nock

Ferdinand Nock, company founder

NOCK stands for uncompromising quality "Made in Germany". This begins with the quality-orientated concept and construction of the NOCK fish skinning machines, comprising of the manufacturing of all central components at the company-own ultra-modern machine park, exclusively using premium base materials and acquired parts, the collaboration with established suppliers, diligent assembling and final inspection of the NOCK machines. An experienced team of highly qualified and motivated employees also contributes significantly to this high quality standard. This results in modern, particularly reliable and durable machines of continuous quality.



NOCK can offer German high class workmanship to interesting prices due to modular construction, modern production methods and strict cost management. An important aspect considering the often tightly calculated investment budgets of fish processing plants.

Freeze Drum Skinner TFE 350



Features and application range

The NOCK Freeze Drum Skinner TFE 350 is a **fish skinning machine with freeze drum technology**, in which NOCK puts his long term fish skinning technology competence and his know how in refrigeration technology from the construction of the NOCK scale ice machines. This results in a fish skinning machine with reliable German machine engineering, high quality, high energy efficiency, easy cleaning and compact dimension. Above this the service friendly construction results in low follow-up costs.

- particularly suitable to skin soft (e.g. defrosted) fish fillets and for all types of fish with weak skin
- to cut fish and other products
- **skinning depth:** up to 10 mm stepless
- **cutting width:** 370 mm
- **cutting speed:** 12 - 24 m/min
- **form of application:** skin side up



Standard equipment

- **energy-efficient freeze drum;** surface hard-anodized
- high quality **refrigeration aggregate** (environment friendly refrigerant means R404A)
- water jets so that the product will freeze reliably on to the freeze drum; low water consumption
- **rotating band knife with high precision guide** for constant and also very thin skinning
- stepless adjusting of skinning thickness by handrail, even during operation
- water jets and scraper keep the band knife clean during operation. Easy cleaning without tools.
- band knife can be simply and quickly replaced
- conveyor equipped with 4 mm round straps and extra drive (motor); can be easily removed from the machine to replace the straps
- stainless steel housing with large smooth surfaces and **special operation mode for easy cleaning after production:** conveyor belt and drum operate, refrigeration aggregate and band knife remain stopped
- mobile machine with lockable castors



Options

- Conveyor belt available with other strap diameters. Follow up alterations also possible
- Available as a split version (separate refrigeration unit)

Cortex CBF 496 • Skinex SB 496



Features and application range

The NOCK Cortex CBF 496 and the Skinex SB 496 are **automatic fish skinning machines with conveyor belts**. The sister models differ in the applied skinning technology and therefore in the favoured suitability:

Cortex CBF 496:

CF-technology. Universal suitability for many fish species, particularly suitable for fish with thick skin, e.g. salmon, salmon trout, flatfish, sea bream, etc.

Also suited to skin fish with thinner skin, however with a lower yield as with the Skinex SB 496.

Skinex SB 496:

S-technology. Particularly suitable for low-loss skinning of fish species with thin skin, e.g. tilapia, pangasius, trout, cod, catfish, cuttlefish, etc.

- **Cutting width:** 430 mm
- **Cutting speed:** 19 m/min
- 3 skinning methods:
 - **deep skinning** with sharp blade
 - **thin skinning (shallow skinning)** with sharp blade
 - **pulling off** the skin a blunt blade (silver skinning)

Standard equipment

- **Cortex CBF 496:** tooth roller with peripheral grooves and scraper comb (CF-technology)
- **Skinex SB 496:** transport roller without peripheral grooves, with counter rotating (dynamic) cleaning roller (S-technology)
- water cleaning unit for reliable constant operation
- blade gap infinitely adjustable
- blade holder spring suspended for perfect skinning results
- special, hard fish pressure unit with adjustable counter weights
- infeed conveyor and output conveyor; can be removed within seconds without any tools; ribbed surface
- foot switch for „manual“ operation on open top machine
- NOCK POWER PLATES® for particular hygiene friendly machine construction, high robustness and service friendly.
- NOCK EASY-FLOW®-safety cover
- lockable steering castors
- stainless steel



Dolphinfish (dorado)

Options

- inflated pressure balloon (soft balloon)
- discharge conveyor belt for removed skin
- transport roller with coarser or finer toothing
- turn around device to automatically skin both sides of flat fish with 2 machines

Cortex CBF 496 SALMON



Features and application range

The NOCK Cortex CBF 496 SALMON is a **skinning machine optimised to automatically skin fresh and smoked salmon** with CF-technology and the innovative NOCK ACTIVE SKIN GRIPPER®.

- **cutting width:** 430 mm
- **cutting speed:** 19 m/min
- **3 skinning methods:**
 - **deep skinning** with sharp blade
 - **thin skinning** (shallow skinning) with sharp blade and NOCK ACTIVE SKIN GRIPPER®
 - **pulling off the skin** (silver skinning) with blunt blade

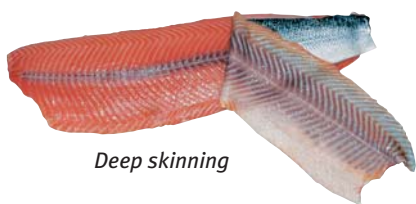

Deep skinning



Thin skinning with sharp blade and ACTIVE SKIN GRIPPER®



Pulling off the skin with blunt blade (silver skinning)



smoked salmon

Standard equipment

- tooth roller with grooves and scraper comb (CF-technology)
- **innovative NOCK ACTIVE SKIN GRIPPER®** for perfect results when thin skinning with sharp blade, without skin surpluses on the tail end of the fillet
- blade gap infinitely adjustable
- blade holder spring suspended
- pressure unit with adjustable balance weights
- **special salmon pressure roller** made of polyamid for a very long roller service life and more pressure on the middle of the fillet (less pressure on the sides = less loss when deep skinning)
- water cleaning unit for reliable continual operation when processing fresh fillets
- infeed and output conveyor; can be removed from the machine within seconds without any tools
- NOCK POWER PLATES®
- NOCK EASY-FLOW®-safety cover
- lockable steering castors
- stainless steel



special salmon pressure roller



Optional: pressure balloon (soft balloon)

Options

- inflated pressure balloon (soft balloon)
- discharge conveyor belt for removed skin
- curved blade holder for further minimization of the dark side muscle when deep skinning
- additional possibility to position the output conveyor belt for easy rejoining of skin and fillet
- transfer plate for passing through the machine without skinning

Skinex QS 888

Features and application range

- conveyORIZED double lane fish skinning machine with S-technology
- enormous capacity: more than 200 fillets/min, depending on the size of the fillets (speed of infeed conveyor belt 29 m/min)
- perfect for skinning tilapia, pangasius (basa), catfish, redfish, cod and other fish species
- silver skinning salmon
- 3 methods of skinning:
 - thin skinning (shallow skinning)
 - pulling-off the skin with blunt blade (silver skinning)
 - deep skinning with sharp blade



Standard equipment

- divided pressure roller (spring suspended) for double lane feeding
- cutting width 2 x 200 mm
- transport roller without grooves with counter rotating cleaning roller made of stainless steel (S-technology)
- water cleaning unit for steady continuous operation
- blade gap infinitely variable
- spring suspended blade holder for perfect skinning results
- special pressure rollers made of polyamide for gentle processing, easy handling and long durability
- infeed and output conveyor belt; can be taken out of the machine within seconds without any tools; ripped surface
- NOCK POWER PLATES® for a machine construction which is easy to clean, for outstanding robustness and service friendliness
- NOCK EASY-FLOW® safety cover
- lockable castors
- stainless steel



Divided pressure roller

Options

- output conveyor belt
- discharge conveyor belt for removed skin
- longer infeed conveyor belt
- transport roller with coarse or fine tothing

Cortex CF 460 • Skinex S 460

Features and application range

The NOCK Cortex CF 460 and the Skinex S 460 are **open top fish skinning machines for manual infeed**.

The sister models differ in the applied skinning technology and therefore in the favoured suitability:

Cortex CF 460:

CF-technology. Universal suitability for many fish species. Especially for fish with thick skin, e.g. salmon, salmon trout, plaice, sole, sea bream, shark etc.

Also suitable to skin fish species with thin skin, however a lower yield than with the Skinex S 460.

Skinex S 460:

S-technology. Particularly suitable for low-loss skinning of fish species with thin skin, e.g. tilapia, pangasius, trout, cod, catfish, squid, etc.

- **Cutting width:** 430 mm
- **Cutting speed:** Cortex CF 460: 19 m/min
Skinex S 460: 29 m/min
- **Skinning methods:**
 - **thin skinning** with sharp blade
 - **pulling off** the skin with blunt blade (silver skinning)
 - restricted: deep skinning with sharp blade (deep skinning)

Standard equipment

- **Cortex CF 460:** tooth roller with grooves and scraper comb (CF-technology)
- **Skinex S 460:** transport roller without grooves, with counter rotating (dynamic) cleaning roller (S-technology)
- water cleaning unit for reliable constant operation
- blade gap infinitely adjustable
- blade holder spring suspended for perfect skinning results
- ergonomic favourable foot switch
- NOCK POWER PLATES® for a machine construction which is easy to clean, for outstanding robustness and service friendliness
- lockable steering castors
- stainless steel



Options

- transport roller with coarse or fine tothing
- feeding unit for safe skinning of small fish

TIP: It depends on the geometry of the blade, the blade holder and the transport roller in particular when thin skinning fish. This geometry is only guaranteed with the original **NOCK TOP H** blades.

The use of other blades can (even with identical measurements) cause higher losses, poor results and short blade service life.

This recommendation applies for all NOCK fish skinning machines.

Cortex CF 420 • Skinex S 420



Features and application range

The NOCK Cortex CF 420 and the Skinex S 420 are **open top table machines to skin fish**. They are a good value solution for the fish trade and an ideal **additional machine in the industrial fish processing industry**. The sister models differ in the applied skinning technology and therefore in the favoured suitability:

Cortex CF 420:

CF technology. Universal suitability for many fish species. In particular suitable to skin fish with thick skin, e.g. salmon trout, plaice, sole, etc.

Skinex S 420:

S-technology. Particularly suitable to skin fish species with thin skin.

- **Cutting width:** 430 mm
- **Cutting speed:** Cortex CF 420: 19 m/min
Skinex S 420: 24 m/min
- **Skinning methods:**
 - thin skinning with sharp blade
 - pulling off the skin with blunt blade (silver skinning)
 - restricted: deep skinning with sharp blade (deep skinning)

Standard equipment:

- **Cortex CF 420:** tooth roller with grooves and scraper comb (CF-technology)
- **Skinex S 420:** transport roller and counter rotating (dynamic) cleaning roller (S-technology)
- water cleaning unit for reliable constant operation
- blade gap infinitely adjustable
- carry handles
- foot switch
- stainless steel

Options

- underframe with steering castors

Cortex CF 300 COUNTERBOY



Features and application range

The NOCK Cortex CF 300 COUNTERBOY is a **small open top table machine** with CF-technology to skin many fish species. Ideal for the shop counter in a fish shop, for supermarkets and the catering industry, however is not suited for industrial use.

- **cutting width:** 280 mm
- **cutting speed:** 19 m/min
- **Skinning methods:**
 - thin skinning with sharp blade
 - pulling off the skin with blunt blade
 - restricted: deep skinning with sharp blade

Standard equipment

- toothroller with grooves and scraper comb (CF-technology)
- water cleaning unit for reliable constant operation
- blade holder infinitely adjustable
- carry handles
- foot switch
- stainless steel

Options

- underframe with 2 castors

Skinning technologies and skinning methods

The CF-technology



The automatic NOCK CBF machine models and the open top NOCK CF fish skinning machines are equipped with a **transport roller with grooves** (tooth roller). A **scraper comb** cuts in the grooves of the tooth roller and keeps it clean during operation.

The CF technology is most suitable **especially to skin fish with thick skin** and offers advantages because of its **universal application for many fish species**.

It is also suitable for fish with thin skin, but with less yield when skinning with sharp blade or pulling-off the skin with blunt blade (silver skinning).

The CF transport rollers are optionally available with coarser or finer toothings.

The S-technology

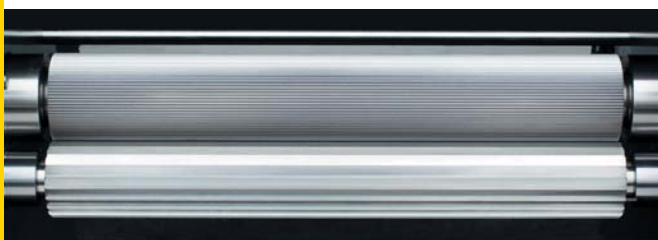

The automatic NOCK SB machine models and the open top NOCK S fish skinning machines are equipped with a **transport roller with fine toothings, but without grooves** and with a **counter rotating cleaning roller made of stainless steel**.

The S technology is **particularly suitable for fish species with thin skin** and achieves the **best yield** when thin skinning with sharp blade and pulling-off the skin with blunt blade (silver skinning). There are limitations when deep skinning with open top machines as they lack of a transportation support of a pressure roller. Depending on the kind of fish and the consistency of the fillets it is not always possible to take advantage of the maximum blade gap for deep skinning.

The S transport rollers are also available with coarser or finer toothings.

An economical **water cleaning unit** supports the cleaning function of the CF and S technologies and therefore guarantees an interference free continuous operation. The water cleaning unit can be deactivated when processing smoked fish.

The freeze drum technology

When processing with the freeze drum technology, the skin of the fillet is sprayed with water and then freezes onto the freeze drum. A rotating band blade separates the skin from the fillet. A scraper removes the skin from the freeze drum.

This technology is particularly suitable for skinning soft (e.g. thawed) fillets and for all fillets with soft (weak) skin.

The NOCK ACTIVE SKIN GRIPPER®

The NOCK ACTIVE SKIN GRIPPER® hinders when thin skinning salmon fillets with a sharp blade that sometimes a skin residue remains on the tail end. For this the slightly opened blade holder is pneumatically closed as soon as the first few millimetres of the skin penetrate the blade holder.

Skinning methods

1. Thin skinning with sharp blade

When **thin skinning (shallow skinning)** with sharp blade, the blade gap is closed so much that nearly no flesh remains on the skin. The blade gap can be adjusted infinitely and sensitively with the lever outside the machine, also during operation.



The spring suspension of the blade holder results in perfect adjustment to various thick skins. This suspension is located in the machine casing.

2. Deep skinning with sharp blade

When deep skinning with sharp blade, the blade holder is opened so far so that a higher or less higher extent of the bordering fat or flesh layer of the fish is removed with the skin. The blade gap can be adjusted infinitely and sensitively with the thickness adjusting lever, also during operation.

In doing this it is possible with some fish species to improve the quality and the attainable fillet price so that the accepted higher weight loss is then evened.

3. Pulling off the skin with blunt blade

When pulling-off, the skin is divided from the fillet with the blunt edge of the blade, so that the silver layer stays on the fillet ("**silver skinning**"). Here the blade is placed in the blade holder with the blunt edge facing forwards and the blade holder is completely closed ("tightened"). So compared to the thin skinning with a sharp blade, the yield can be further increased and the desired appearance of the fillets with silver layer is achieved for some fish species.

Machine equipment / Fish skinning machines

machine model	automatic machine with infeed and output conveyor	open top stand machine	open top table machine	underframe	skinning technology	skinning modes			blade holder spring suspended	NOCK ACTIVE SKIN GRIPPER®	NOCK POWER PLATES®	NOCK EASY-FLOW® safety cover	lockable castors	stainless steel
						silver skinning	thin (shallow) skinning	deep skinning						
Freeze Drum Skinner TFE 350	<input checked="" type="checkbox"/>				GF	<input checked="" type="checkbox"/>	<input checked="" type="checkbox"/>	<input checked="" type="checkbox"/>	rotating band knife	<input checked="" type="checkbox"/>	<input checked="" type="checkbox"/>	<input checked="" type="checkbox"/>	<input checked="" type="checkbox"/>	<input checked="" type="checkbox"/>
Cortex CBF 496	<input checked="" type="checkbox"/>				CF	<input checked="" type="checkbox"/>	<input checked="" type="checkbox"/>	<input checked="" type="checkbox"/>	<input checked="" type="checkbox"/>	<input checked="" type="checkbox"/>	<input checked="" type="checkbox"/>	<input checked="" type="checkbox"/>	<input checked="" type="checkbox"/>	<input checked="" type="checkbox"/>
Cortex CBF 496 SALMON	<input checked="" type="checkbox"/>				CF	<input checked="" type="checkbox"/>	<input checked="" type="checkbox"/>	<input checked="" type="checkbox"/>	<input checked="" type="checkbox"/>	<input checked="" type="checkbox"/>	<input checked="" type="checkbox"/>	<input checked="" type="checkbox"/>	<input checked="" type="checkbox"/>	<input checked="" type="checkbox"/>
Skinex SB 496	<input checked="" type="checkbox"/>				S	<input checked="" type="checkbox"/>	<input checked="" type="checkbox"/>	<input checked="" type="checkbox"/>	<input checked="" type="checkbox"/>	<input checked="" type="checkbox"/>	<input checked="" type="checkbox"/>	<input checked="" type="checkbox"/>	<input checked="" type="checkbox"/>	<input checked="" type="checkbox"/>
Skinex QS 888	<input checked="" type="checkbox"/>				S	<input checked="" type="checkbox"/>	<input checked="" type="checkbox"/>	<input checked="" type="checkbox"/>	<input checked="" type="checkbox"/>	<input checked="" type="checkbox"/>	<input checked="" type="checkbox"/>	<input checked="" type="checkbox"/>	<input checked="" type="checkbox"/>	<input checked="" type="checkbox"/>
Cortex CF 460		<input checked="" type="checkbox"/>			CF	<input checked="" type="checkbox"/>	<input checked="" type="checkbox"/>	<input checked="" type="checkbox"/>	<input checked="" type="checkbox"/>	<input checked="" type="checkbox"/>	<input checked="" type="checkbox"/>	<input checked="" type="checkbox"/>	<input checked="" type="checkbox"/>	<input checked="" type="checkbox"/>
Skinex S 460		<input checked="" type="checkbox"/>			S	<input checked="" type="checkbox"/>	<input checked="" type="checkbox"/>	<input checked="" type="checkbox"/>	<input checked="" type="checkbox"/>	<input checked="" type="checkbox"/>	<input checked="" type="checkbox"/>	<input checked="" type="checkbox"/>	<input checked="" type="checkbox"/>	<input checked="" type="checkbox"/>
Cortex CF 420			<input checked="" type="checkbox"/>	<input type="checkbox"/>	CF	<input checked="" type="checkbox"/>	<input checked="" type="checkbox"/>	<input checked="" type="checkbox"/>					<input checked="" type="checkbox"/>	<input checked="" type="checkbox"/>
Skinex S 420			<input checked="" type="checkbox"/>	<input type="checkbox"/>	S	<input checked="" type="checkbox"/>	<input checked="" type="checkbox"/>	<input checked="" type="checkbox"/>					<input checked="" type="checkbox"/>	<input checked="" type="checkbox"/>
Cortex CF 300 COUNTERBOY			<input checked="" type="checkbox"/>	<input type="checkbox"/>	CF	<input checked="" type="checkbox"/>	<input checked="" type="checkbox"/>	<input checked="" type="checkbox"/>					<input checked="" type="checkbox"/>	<input checked="" type="checkbox"/>

Other options (depending on machine model):

- inflated pressure balloon (soft balloon)
- discharge conveyor for removed skin
- transport roller with coarse or fine toothing
- foot switch for „manual“ operation with an open conveyor machine
- turn-around device to skin both sides of flat fish

standard

optional

1 restricted

2 freeze drum hard-anodized

CF = tooth roller with scraper comb

GF = freeze drum

S = transport roller without grooves, with counter rotating cleaning roller

Technical data / Fish skinning machines

machine model	cutting width	cutting performance	blade gap (stepless)	maximum throughput height	apply length on infeed belt	overall measurements W x H x D	weight	motor performance	electrical connection	water connection	approx. water consumption	compressed air
Freeze Drum Skinner TFE 350	mm 370	m/min 12 - 24	mm 0 - 10	mm 40	mm 480	mm 1500 x 1500 x 2600	kg 780	kW 5-0	3 AC - 400 V - 50 (60) Hz	G 3/4" external thread	l/h 200	bar -
Cortex CBF 496	430	19	0 - 5	70	400	800 x 1190 x 1860	240	0.75	3 AC - 400 / 230 V - 50 (60) Hz ^①	G 1/8" female thread	200	-
Cortex CBF 496 SALMON	430	19	0 - 5	70	400	800 x 1190 x 1860	250	0.75				
Skinex SB 496	430	19	0 - 5	70	400	800 x 1190 x 1860	240	0.75				
Skinex QS 888	2 x 200	29 ^②	0 - 2	40	540	800 x 1190 x 1820	240	1.1				
Cortex CF 460	430	19	0 - 4	-	-	740 x 960 x 630	150	0.75				
Skinex S 460	430	29	0 - 4	-	-	740 x 960 x 630	160	0.75				
Cortex CF 420	430	19	0 - 3.5	-	-	700 x 420 x 500 (700 x 950 x 600) ^③	80 (95) ^③	0.75				
Skinex S 420	430	29	0 - 3.5	-	-	700 x 420 x 500 (700 x 950 x 600) ^③	80 (95) ^③	0.75				
Cortex CF 300 COUNTERBOY	280	19	0 - 3.5	-	-	560 x 320 x 400 (560 x 950 x 500) ^③	50 (65) ^③	0.25				

^① other voltages available upon request

^② speed of infeed conveyor belt

^③ with underframe

NOCK Maschinenbau GmbH
 Industriestrasse 14
 77948 Friesenheim
 GERMANY

Tel: +49 (0) 7821-92 38 98-0
 Fax: +49 (0) 7821-92 38 98-18
 E-mail: info@nock-gmbh.com
 www.nock-gmbh.com